

4 TYPICAL MUNTIN DETAIL
SCALE: 1'-0" = 1'-0"

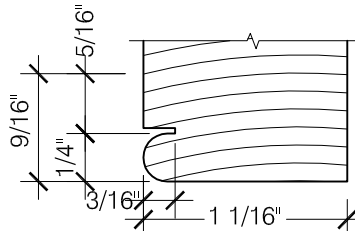

5 TYP. DETAIL OF SCROLL WORK AT BRICK MOLD
SCALE: 1'-0" = 1'-0"

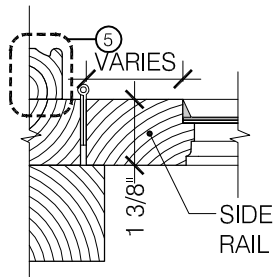

3 SECTION AT JAMB
SCALE: 3" = 1'-0"

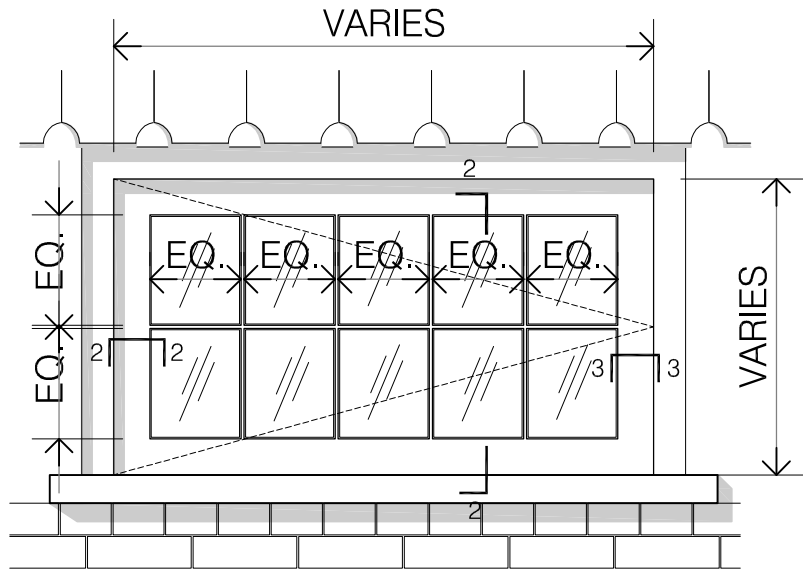

1 WINDOW ELEVATION
SCALE: 1" = 1'-0"

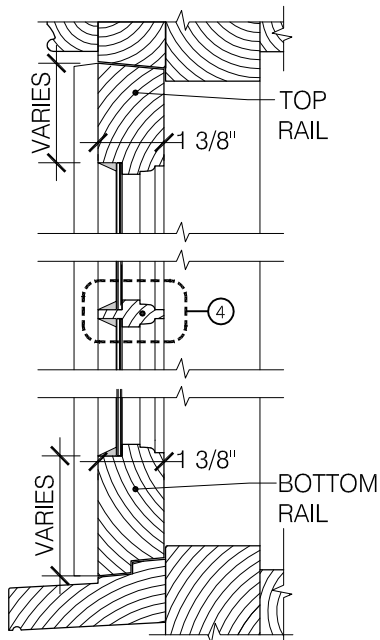

2 SECTION AT JAMB
SCALE: 3" = 1'-0"

GENERAL NOTES:

THIS DRAWING ILLUSTRATES THE PERCEIVED ORIGINAL DESIGN INTENT OF THE WINDOW TYPE NOTED BELOW, AND IS TO BE REFERENCED ONLY AS A GUIDE IN PREPARATION OF FABRICATION DRAWINGS FOR WINDOW REPLACEMENT. VERIFICATION OF ALL EXISTING SITE CONDITIONS, DIMENSIONS AND APPLICABLE CODES IS THE RESPONSIBILITY OF THE FABRICATOR, INSTALLER OR OWNER. ALL PERFORMANCE CRITERIA AND OPERATIONAL CHARACTERISTICS ARE TO BE DETERMINED BY THE OWNER. THIS DRAWING IS NOT FOR CONSTRUCTION.